

WHIRLWIND  
**RoughRider™**  
**USER MANUAL**



## Whirlwind RoughRider™ User Manual

Copyright © 2007 by Whirlwind Wheelchair International  
First Edition, June 2007

Written by  
Alida Lindsley & Carol Maddox

Contributions  
Chris Howard & Ralf Hotchkiss

Editors  
Joan Rogin & Marc Krizack

Dear Wheelchair Rider,

Congratulations on your new Whirlwind RoughRider. Now you are part of a global network of wheelchair riders who break society's rules on where we should ride, what we should become, and what obstacles we can overcome together.

The RoughRider is the culmination of the inventiveness of over 300 wheelchair users, in over 22 countries, who gave direct input on the design. Their imagination was sparked from their own daily experience using wheelchairs in the rough conditions where they live. From the huts of central Africa, to the squatter cities of Nicaragua, to the rural plains of the USA, wheelchair riders are getting out into the world and proving that they can get things done.

This is a chair you can work on. I hope you'll take your RoughRider apart soon, get to know how easy it is to work with, and learn to maintain it to last for decades.

In this wheelchair you will go places where most wheelchairs get stuck. You've probably already dreamed of trips to the park and even out to the wild places. If you're hoping bring home a big fish or just make it down a rough sidewalk without getting thrown, I'll bet you'll have a great trip.

In your RoughRider you'll go more places, do more things, keep riding for years. We look forward to hearing about your adventures. Please stay in touch.

Check for pressure sores and keep your wrench in your shirt pocket,

Ralf Hotchkiss

The RoughRider's design is the culmination of ideas and innovations of wheelchair builders, users, and experts from around the world who promote the independence of wheelchair riders.

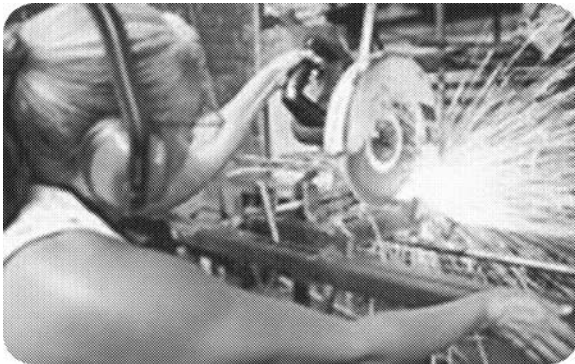

Thelma Ramos of Chinandega,  
Nicaragua



Thelma Ramos of Chinandega,  
Nicaragua

**WARNING:** DO NOT USE THIS WHEELCHAIR WITHOUT FIRST READING AND UNDERSTANDING THIS MANUAL – OTHERWISE INJURY AND/OR DAMAGE TO THE WHEELCHAIR MAY OCCUR. PLEASE PAY SPECIAL ATTENTION TO THE BOXES LABELED “**WARNING**”, “**CAUTION**”, AND “**IMPORTANT**”.

## Table of Contents

<b>Your RoughRider</b>	<b>1</b>
Who is the RoughRider for? And RoughRider Specifications	2-3
RoughRider Components	4
RoughRider Features	5
Common Modifications	9
<b>Basic Riding Skills</b>	<b>11</b>
Know your Capabilities and Limits	11
Pressure Relief	14
Pressure Relief Techniques	16
Moving Around	19
Riding Techniques	19
Transfers: Getting in and out of your RoughRider	20
Traveling with your RoughRider	24
<b>Maintenance and Repair</b>	<b>31</b>
Maintenance Schedule	32
Bearings	33
Upholstery	35
Wheel Locks	40
Spokes	42
Lubricating your RoughRider	43
Tires	45
Cleaning your RoughRider	46
Routine Inspections	48
Nuts and Bolts	49
Footrests	50
Handgrips	52
Troubleshoot: If your RoughRider Does Not Roll Straight	53
	54

**WARNINGS:**

- DO NOT use an escalator to move a wheelchair between floors. Serious bodily injury may occur.
- DO NOT lean over the top of the back upholstery to reach objects from behind as this may cause the wheelchair to tip over.
- DO NOT shift your weight or sitting position toward the direction you are reaching as the wheelchair may tip over backwards or sideways.
- DO NOT tip or wheelie the wheelchair without assistance, unless you are highly skilled.
- DO NOT attempt to stop a moving wheelchair with wheel locks. Wheel locks are not brakes.
- DO NOT stand on the frame of the wheelchair.
- DO NOT over-inflate the tires.
- ALWAYS use caution when transferring in or out of the wheelchair. Every precaution should be taken to reduce the transfer distance. Also be certain the wheel locks are engaged to prevent the wheels from moving.

## CAUTIONS:

- **Riding over curbs or obstacles can cause tipping and serious bodily harm.** If you have any doubt that you can safely cross any curb or obstacle, ALWAYS ASK FOR HELP. Be aware of your riding skills and personal limitations. Develop new skills only with the help of a companion.
- Using **Anti-Tippers substantially reduces your risk of falling over backwards**, which can cause serious injury. If you are afraid of tipping over, use the Anti-Tippers. The Anti-Tippers will keep you from falling over, but they will limit your ability to be pulled up curbs and some other maneuvers. Just as children learn to ride bikes without training wheels, you may be able to learn to use your wheelchair without Anti-Tippers. **WHIRLWIND STRONGLY RECOMMENDS THAT YOU USE ANTI-TIPPERS WHILE YOU ARE LEARNING TO RIDE YOUR WHEELCHAIR.**
- Always wear your **seat positioning strap**. Whirlwind recommends using a seat positioning strap as an additional safeguard against falling out of your wheelchair. If your seat positioning strap becomes lost or worn, contact Whirlwind for a replacement.
- The RoughRider is not designed for **weight training** and is unsafe for use as a seat while weight training. Weight training from the RoughRider substantially changes the stability of the chair and may cause tipping.



## Your RoughRider®



The **RoughRider** wheelchair's innovative design helps you **ride more easily and safely**:

- Over rough ground without tipping forward.
- Over soft surfaces, without the front wheels getting stuck.
- Down and across slopes, with minimal effort and much less risk of tipping.

The RoughRider is compact, **tough**, and has a **comfortable** seat.

The RoughRider's folding frame makes **travel easy** on buses and automobiles. The RoughRider was designed with few removable components to minimize the loss of parts.

The RoughRider was also designed for **easy repair and maintenance** using commonly available parts and tools.





**CAUTION****Who is the RoughRider for?**

To avoid potential injury, the RoughRider should only be used by someone who can meet the following criteria:

**Pressure Management - *The single most important criterion.*** If you have limited or no sensation (feeling) you must be able to manage the pressure on your body to use the RoughRider safely (e.g., proper techniques for self care, pressure relief, skin care). A pressure ulcer can form after only 20 minutes of sitting without pressure relief. You must always have an appropriate, high quality pressure relief cushion (and know how to care for it) to use with the RoughRider.

**Head and Trunk Control** - The RoughRider's sling-type backrest may not be suitable for you if you have weak or absent trunk muscles, as you may not have enough muscle support to maintain a desirable riding position. Using the RoughRider with inadequate trunk control could lead to the development of scoliosis (curvature of the spine). If you are not able to support your head independently, you should not use the RoughRider, as it does not provide any head support.

**Size and Fit** – The RoughRider is designed for riders with hip widths between 31.5–48.5 cm\* (12.5–19 in.), and an upper leg length longer than 40.7 cm (16 in.). The length measurement is taken while seated and measures from back of pelvis to back of lower leg. With some standard modifications however, the RoughRider may be suitable for riders outside of these ranges. See end of section for more information. \*Seat widths may vary depending on manufacturer.

**Rider Weight** – The RoughRider is designed and rigorously tested for riders up to 220lbs in weight. Riders who weigh over 220 lbs should not use the RoughRider because the wheelchair may be unstable and tip over.

**WARNING****Where can you go in your RoughRider?**

**Obstacles and slopes** – The RoughRider is designed to perform well on some rough surfaces and provide for independent navigation of some obstacles. Because of the great variety of surfaces and obstacles you will encounter, Whirlwind's does not claim that the RoughRider will be stable in all circumstances. Whirlwind recommends EXTREME CAUTION when traversing uneven surfaces and slopes. ALWAYS use an assistant when necessary. Whirlwind is not liable for bodily injury resulting from use of the RoughRider. Users travel AT THEIR OWN RISK and Whirlwind recommends using good judgment and caution before traveling over obstacles or on rough, uneven, sloped terrain. Please be safe and AVOID INJURY.

## RoughRider Specifications

Effective Seat Widths: *	14 in., 15.7 in., 17.4 in., 19 in.*
Seat Depth:	16 in.
Seat Height:	19 in. at front of seat
Seat Angle:	12 degrees
Seat to Back Angle:	90 degrees
Back Height:	17 in. standard, 15 in. and 19 in. custom
Footrest Height from Front of Seat:	10–14.75 in.
Rear Wheel Dimensions:	24 x 1.75 in. standard
Rear Wheel Camber:	3 degrees
Rear Wheel & Caster Barrel Bearings:	6201 (12mm ID x 32mm OD)
Axles:	1/2 in.
Push Rim Diameter:	19 in.
Front Wheel Dimensions:	4.3 in. diameter x 3.1 in. width
Front Wheel Bearings:	Standard bicycle hub and bearing
Overall Width:	9 in. + Seat width
Overall Length:	Shortest 36 in.; longest 39 in.
Wheelbase (Front to Rear Axle):	Shortest 19 in.; longest 22 in.
Rear Wheel Position Adjustment:	5 positions over 3 in.
Weight:	41 lbs

\*seat fabric will be narrower than effective seat width

\*\*RoughRider specifications: numbers are approximate



# RoughRider™ Components

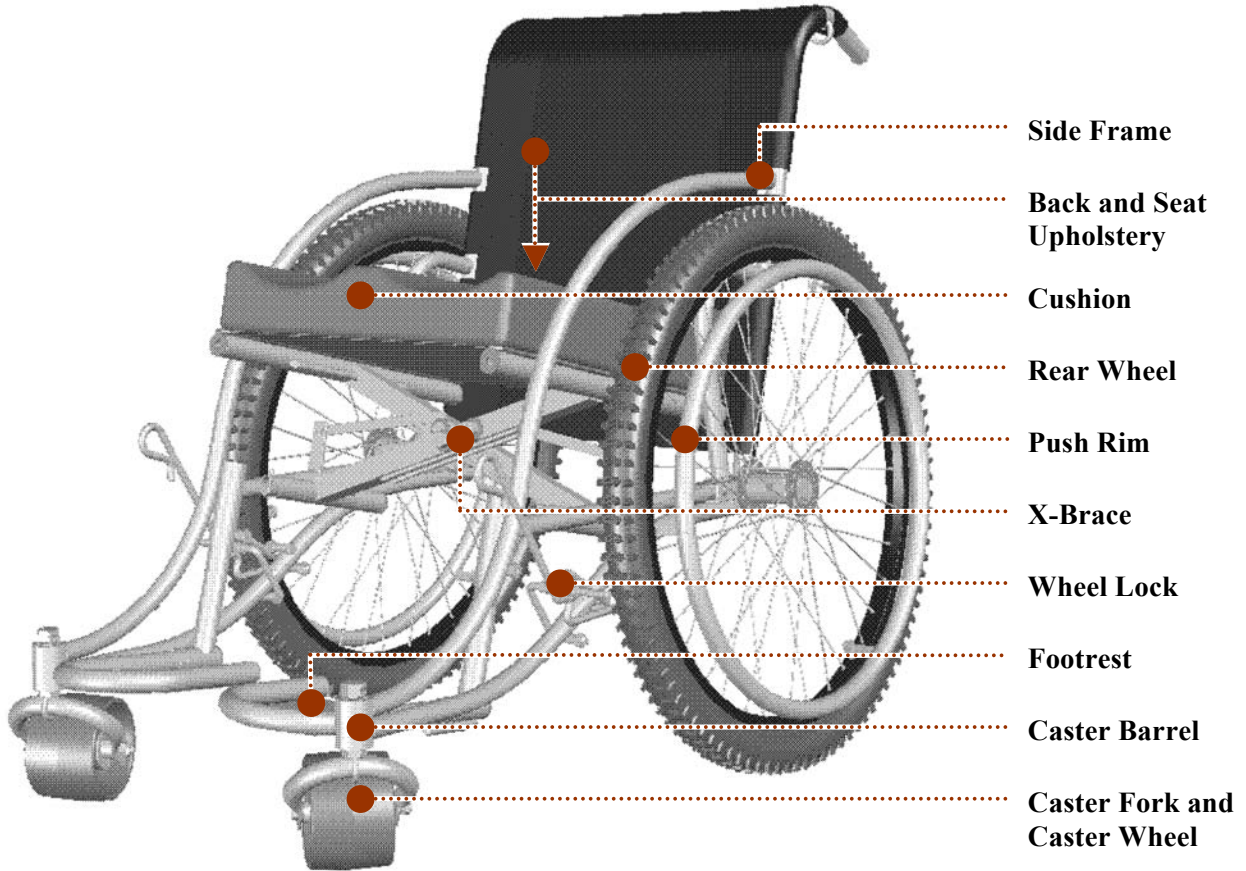

## IMPORTANT

Upon receiving your RoughRider, please make a note of how the components are adjusted so that you can easily adjust them in the future. It is recommend that you write down the following critical measurements and refer to them when performing inspections or maintenance on your RoughRider:

<b>Seat Width</b>	_____ in.	(measured between inside edges of side frames)
<b>Seat Height</b>	_____ in	(measured from floor to front edge of seat)
<b>Footrest Height</b>	Right _____ in	(measured from front edge of seat to back edge of foot plate)
	Left _____ in	



## RoughRider™ Features

### Long Wheelbase

Small diameter caster wheels fit under the footrests, resulting in a longer distance between the rear wheels and caster wheels without making the chair longer overall. The small wheels also allow you to maintain a low knee height, so that your knees can fit under tables.

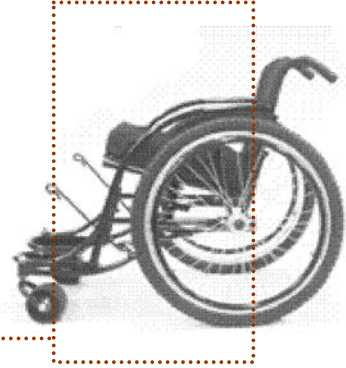

#### What are the advantages of a longer wheelbase?

- **Prevents tipping** (better forward stability) when traveling over uneven terrain, such as rocks or uneven dirt roads.
- **Easier to push** because more weight is on the rear drive wheels, and less on your front caster wheels, which gives you better traction on uneven ground and makes it easier to roll straight on a side slope.

### Foldable X-Brace



#### Why have a foldable X-brace?

- Chair folds flat for **easy storage and transport**. If your chair does not fit under or behind the rear seat of a van or bus, you could be charged double or triple for transport.
- **Chair width can be easily changed** by substituting a different size X-brace and upholstery.



## Pneumatic Rear Tires



Most RoughRiders come with all terrain pneumatic tires (mid to heavy-weight), that fit on standard wheel rims (24 x 1.75 in.) However, you might prefer light-weight tires and rims if you will be mostly riding indoors or in well-paved urban environments.

### Why use pneumatic (air filled) rear tires?

Because wider, sturdier, pneumatic tires provide better:

- **Shock absorption** - air filled inner tubes absorb bumps better than standard hospital wheelchair tires that are made of solid rubber.
- **Durability** - thicker, knobbier tires last longer on rough roads than standard wheelchair tires that are thin and have little tread.
- **Repair and replacement options** - pneumatic tires are available wherever bicycle parts are sold and eliminate the need to search for special wheelchair tires. Solid rubber tire inserts may be an option to avoid punctures.



## Wheel Locks



“Parking Brakes” Stabilize your chair *when it is stopped* for easier and safer transfers, reaching, weight shifting, etc.

Parking brakes should not be used to slow the chair because it will quickly wear down the tread of the tires.



## “Zimbabwe” Caster Wheels



### Why use “Zimbabwe” caster wheels?

- The flexible rubber design provides a **smooth ride over rough ground** including cracks, stones, and other small obstacles.
- The wide wheel “floats” over soft ground without getting stuck.
- The V-tire profile **reduces the sticky contact area** of the tire so that it swivels easily on hard surfaces.



## Adjustable Rear Wheel Position

The RoughRider's rear wheels have five positions.

### Why have an adjustable rear wheel position?

An adjustable rear wheel position **optimizes stability and performance** for riders of differing abilities.

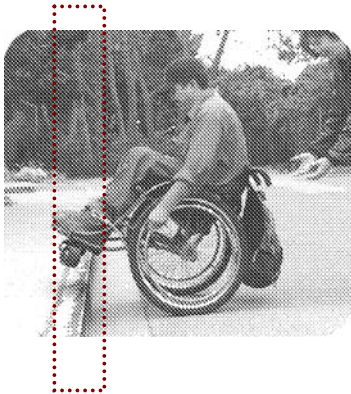
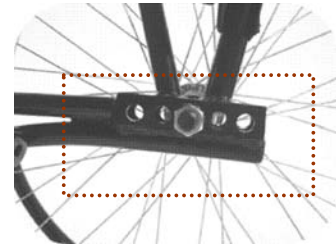

With your rear wheels further forward:

- Your chair will be easier to push because there is less weight on the front wheels.
- Your chair will resist turning downhill on a side slope.
- It will be easier to go over obstacles.
- It will be easier to perform wheelies.

With your rear wheels further back the chair will be less likely to tip backward.

Start with the rear wheel in a position that feels secure to you. As your skill level increases with practice, the wheel position can be adjusted forward.

## Your Cushion

If you have limited feeling in your buttocks, you should use a high quality foam cushion that is highly resilient. If you do not use a suitable cushion you are likely to develop a pressure sore. You should also perform regular pressure relieving exercises (see the Basic Riding Skills section for more instruction and information about limited feeling).

A cushion can also make you feel more comfortable and can promote good posture. If you use a cushion, make sure your footrests are well adjusted so that your weight is evenly distributed on the cushion.

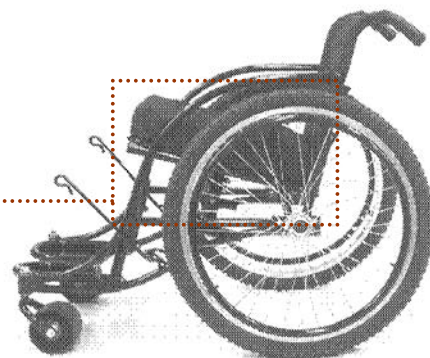

## Seat Angle

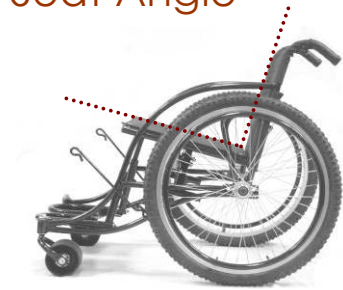

The RoughRider was designed with 12 degrees of seat tilt.

### Why does the RoughRider have seat tilt?

- Seat tilt makes sitting **feel more natural and comfortable**; the back-tilted position helps keep your trunk upright.
- Seat tilt helps you **resist falling forward** out of the chair (e.g. when you are stopped suddenly by a bump).

### Standard chair with little seat tilt

Rider slumps forward and uses effort to sit.



### RoughRider with 12 degrees seat tilt

Rider can reach farther back to push and can sit upright with less effort.



## Cambered Rear Wheels

Cambered wheels tilt inward at the top of the wheel and outward at the bottom. The RoughRider has approximately 3 degrees of camber.

### Why have cambered wheels?

- **More stability** side to side because the chair is wider at the bottom.
- **Easier to push** the push rims because they are in line with your shoulders, closer to you, and angle outwards slightly.

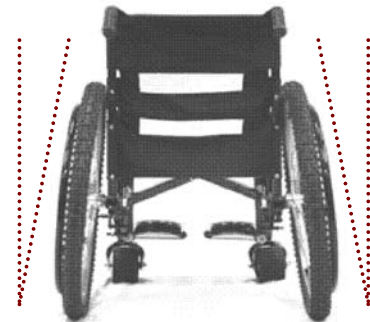

## Footrests

The RoughRider's footrests:

- **Are adjustable** to accommodate users of different heights.
- **Fold** out of the way for easier transfer.

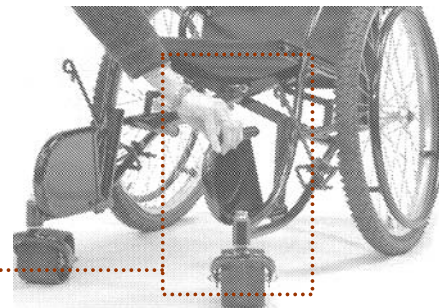



## Common Modifications

### For Shorter Riders

**Shorter Seat Depth** - If your upper legs are shorter than 40.7mm (16 in.), as measured from back of pelvis to back of lower leg, you can shorten the effective seat length by:

- Asking the manufacturer (or a local metalworker) to **shorten the seat tubes** at the front and to make custom seat fabric to fit the new sized tubes;
- Adding **foam behind your back** so that you are sitting further forward (you may also want to move your rear wheels forward).

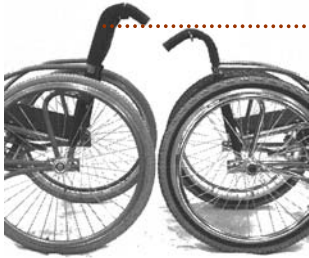
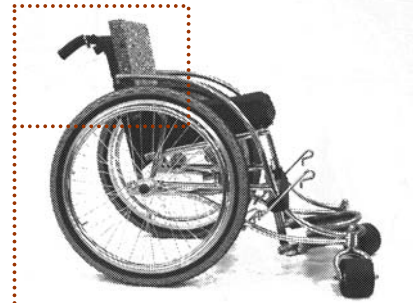

**Shorter Back Height** – Some manufactures may be able to customize the back height for you, if you prefer a shorter back height.

### For Taller Riders

If you are taller than 1.8m (6 ft.), you may need to make some modifications to make the chair fit better. This is especially important if you do not have full feeling in your body.

In order to bear more weight under your thighs and less on your buttocks to prevent pressure sores, you can:

- **Adjust footrests** to their lowest position.
- **Add dense foam under your normal cushion** to lift you up, if your thighs are still not bearing weight.
- **Adjust your wheel position** backward to stabilize your higher center of gravity.
- **Ask your manufacturer** (or local metalworker) to make a **higher backrest** for you. A higher backrest may be more comfortable and support you better.

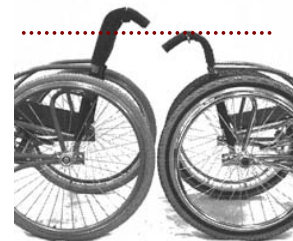
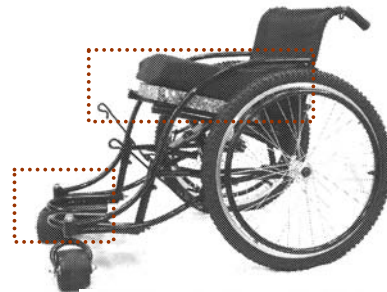



## Optimal Riding for Amputees

If you do not have legs, you may want to:

- **Move your rear wheels back** to prevent yourself from tipping backward.
- **Remove the footrest(s)** to minimize the weight of the chair, unless you use the footrests to carry loads or get in and out of the chair.

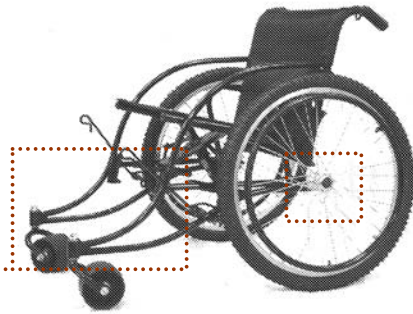

## Calf Strap and Lap Belt

You may want to add a **calf strap** to your RoughRider to **keep your feet from slipping** backward off the footrests. You can add a calf strap by wrapping a piece of material, such as webbing or heavy cloth, around the footrest tubes.

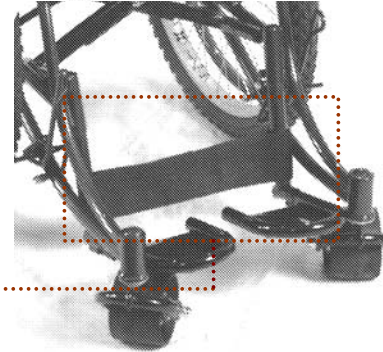

A **seat positioning belt** may be useful to **improve your control** and keep your buttocks seated in the wheelchair. A lap belt can also help you feel more secure when riding your wheelchair. You can add a lap belt by attaching two strips of soft material, such as webbing, to the guide tubes (the inner curved tube on side frame) or to the back tubes and connecting the strips together with a buckle.



## WARNING

**Prevent areas of high pressure:** It is very important **when using both the lap belt and the calf strap** to prevent the strap material from creating areas of high pressure. If you use a calf strap or lap belt make sure to routinely check the skin of your lap and the back of your legs and feet for signs of pressure sores. Refer to the Basic Riding Skills section for more instruction and information about limited feeling and skin checks.



## Know Your Capabilities and Limits

### WARNING

The first step in learning how to ride your RoughRider wheelchair is to know its capabilities and limitations. To avoid injury, you also need to know your own capabilities and limitations. This knowledge will help you decide what you can do on your own and when you will need to ask for help.

### Get a Helper

**Have your helper hold a strap under the push handles**

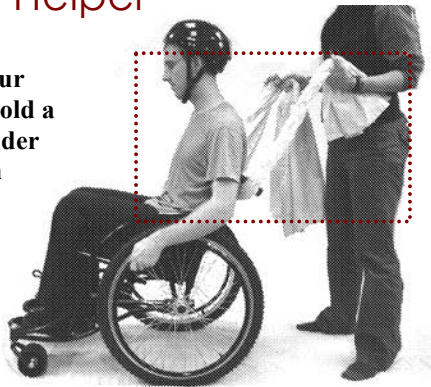

Find someone who can help prevent you from falling or tipping over while you practice riding in your new RoughRider. It is recommended that your helper be with you at all times while you practice.

The helper should stand where he/she can catch you or the chair and stop you from falling. The safest way this can be done is to have your helper hold a strap or rope looped under the push handles. This configuration minimizes the stress on the helper's back, should he or she need to catch your chair.

### Wear a Safety Helmet

Until you are experienced in using your wheelchair, we recommend that you wear a safety helmet. The best helmets will protect the back portion of your head, but do not restrict your vision.



## Lock Your Wheels

### Why should you lock your wheels?

Locking your wheels, so they can't move easily, makes it easier and safer to reach, stretch, and bend over. Make sure the tires are fully inflated and the brakes are adjusted to hold the wheels tightly.

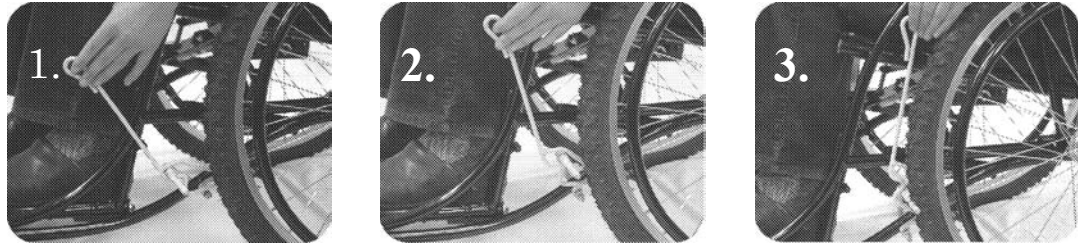

Unlocked ← ..... → Locked

### How to lock your wheels:

- Grab the wheel lock lever.
- Pull the level up and all the way back (if the wheel locks are adjusted correctly, the brakes should push in a bit on the tires. If the wheels are properly locked, it will be very difficult, if not impossible, for the wheels to roll.
- To **unlock the wheels**, push slightly out and then down on the lever.

## Shifting your Weight

It is important for you to know how far you can lean forward in your chair without tipping it over or falling out of it. You must learn how far you can lean while still being able to return to an upright sitting position. Try the following exercises with your helper on hand to assist you and keep you from falling:

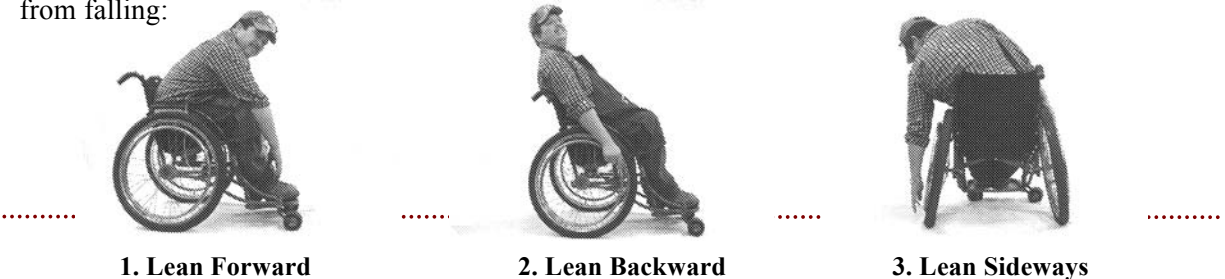

1. Lean Forward

2. Lean Backward

3. Lean Sideways

### Why lean forward?

Lean forward to prevent tipping backward when you go:

- Up hills/ramps.
- Over curbs or up stairs.
- Over obstacles (such as thresholds).
- Down steps/curbs, in a backward position.

.....  
Leaning forward when going uphill



**Why lean backward?**

Lean backward to **prevent falling forward or tipping forward** when you go:

- Downhill.
- Down steps.
- Over curbs.

Leaning backward also distributes more weight on the rear drive wheels, and less on your front caster wheels, which:

- Gives you **better traction** on uneven ground.
- Makes it easier to **roll straight** on a side slope.

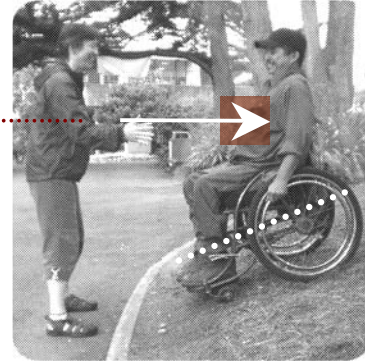

**Leaning back when going downhill**

**Why lean sideways?**

Lean sideways to prevent you and your chair from tipping over sideways when you:

- Travel across the side of a slope.
- Turn on a hill or ramp.



**Leaning sideways when going across a hill**

**IMPORTANT**

To help you learn how steep a slope (up/down/sideways) you can handle without tipping over, practice on slopes and uneven terrain with someone who will help keep you from falling. Practicing with a helper will give you experience in knowing when you will need help in the future.



## Pressure Relief

This section is for riders who:

- Do not have full feeling in their bodies, or
- Have poor blood circulation in their lower body, or
- Have a history of pressure sores, or
- Are at risk of developing a pressure sore.

### IMPORTANT

#### Why is pressure relief important?

- A pressure sore can develop in as little as 20 minutes if you have been sitting on the wrong surface.
- Pressure sores can develop on any part of the body.
- Pressure sores can result in infections and complications that are among the most common causes of death for wheelchair users worldwide.
- Factors that contribute to the development of pressure sores include prolonged, unrelieved pressure over bony areas of the body, shear force, heat, moisture, friction, and trauma.

People with full feeling in their buttocks and legs frequently adjust their sitting position to relieve the discomfort that can result from pressure after sitting only a few minutes in one position. **If you do not have full feeling in your buttocks and legs**, it is important that you shift your weight while riding, so that you are not seated in the same position for too long. When you are seated, your pelvic bones put pressure on the muscles, tissues, and skin underneath them. Skin requires a constant flow of blood, and when too much pressure is placed on the skin, for example, when a person is seated in the same position for too long, the blood cannot flow to the skin and without blood the skin can die. This causes pressure sores which can take a very long time to heal and can even result in death. An infection very similar to a pressure sore can also develop from a cut or scratch that hasn't been properly cared for and is in an area of high sitting or lying pressure. **It is very important to take measures to prevent pressure sores.**



**Stage 4 Pressure Sore.**  
**At Stage 4, the sore extends into muscle, tendon, or even the bone.**

## How to Prevent a Pressure Sore

**Use a pressure relief cushion.** If you have limited feeling in your buttocks, you should use a good quality cushion made from firm foam that is highly resilient and springs back when compressed. Be sure to replace the cushion when it starts to show signs of wear— signs of wear indicate that your cushion is not relieving sitting pressure as well as it should.

**Do pressure relief exercises.** Lift your weight off your seat for 10-60 seconds at least once every 10-20 minutes (see following pages for how to do pressure relief exercises). If you have poor circulation and/or decreased feeling in your legs and buttocks, you should do longer and more frequent weight shifts; if you have feeling in your legs and buttocks and/or you are able to move around while sitting, you can do shorter weight-shifts. Regardless of your current physical capabilities, if you have had pressure sores in the past, you should perform more frequent and longer weight shifts. You should also shift position at least every 2 hours while in bed, and make sure your skin is kept clean and dry.

**Do skin checks twice each day (once in the morning and once at night).** You can use a mirror to inspect areas you cannot easily see. If you are not able to see all areas of your skin, you may need to have a friend or family member check your skin for you. Examine your skin, especially on or around bony areas, looking for red or dark areas if you are light-skinned, or light, dry, flaky or ashy areas if you are darker-skinned. Discoloration should go away within 30 minutes after pressure has been released. Other signs of a pressure sore are skin that is warmer than normal and a hardening under the skin.

**Good Nutrition.** You can help keep your skin healthy if you eat a well balanced diet and drink plenty of water to stay hydrated.

**If you see signs that pressure sore damage to the skin has already occurred, KEEP YOUR WEIGHT OFF THE AREA AND SEEK TREATMENT IMMEDIATELY.**



## Pressure Relief Techniques

**Remember: Shift your weight at least every 10-20 minutes. Each weight shift should last from 10 to 60 seconds.**

### Push-Up

If you have good strength in your arms, you can do a push-up by putting your hands on the wheels or push rims and then pushing up until your buttocks are off the cushion.



**Push Up**

### Forward Weight Shifts

**Lean forward** so your body rests on your knees and the weight is lifted off your buttocks.

You can also try **putting your feet on the ground** (lock your brakes first!) to allow you to lean even farther forward and take more weight off your buttocks.



**Lean forward**

**Feet on ground**

If you find that when you lean forward you cannot sit back up without assistance try one of these alternate techniques.

Reach back and hold on to or **hook your wrists around the back posts** before leaning forward.



**OR, hook wrists around back posts**

Make loops by sewing or tying pieces of webbing, strong cloth or soft, thick rope (about 30cm or 12" long) to make a circle. Hook one loop over each push handle, and **hook your wrists through the loops** before you lower your chest down to your lap. With practice, you might be able to pull yourself back up to sitting.

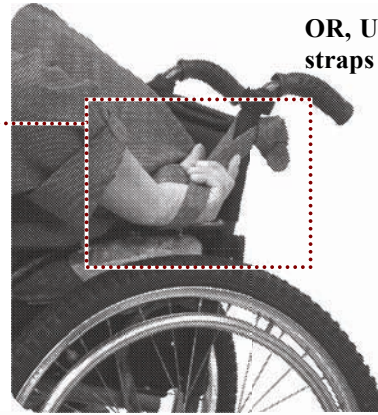

**OR, Use extension straps**

Lean forward and **rest your arms and upper body on a table or desk.**

If you choose to use this technique, you should check or have someone else **check to make sure that your weight really is off your buttocks.** It should be possible for you or the other person to fit a hand between your buttocks and the cushion of your chair without too much effort.

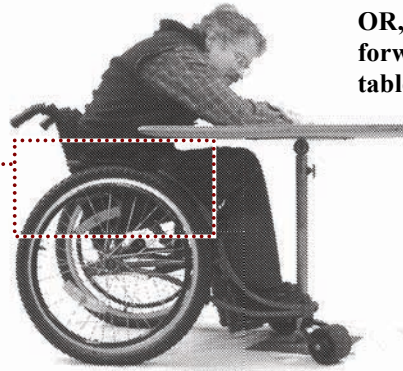

**OR, lean forward on a table**

## Side-to-Side Weight Shifts

**Do this once on each side.**

Get next to a horizontal surface such as a desk, table, bed or other surface which is low enough for you to lean on. Rest your forearm and hand on the surface and lean on it. Then push with your other hand against the opposite side wheel/push rim so you lean farther. This will lift your buttocks up off the seat slightly.



**Lean on table and push up**

OR, put your hands on the wheels/push rims and lean to each side, lifting your buttocks off the surface first on one side, and then on the other, OR, just lean as far as possible to either side.

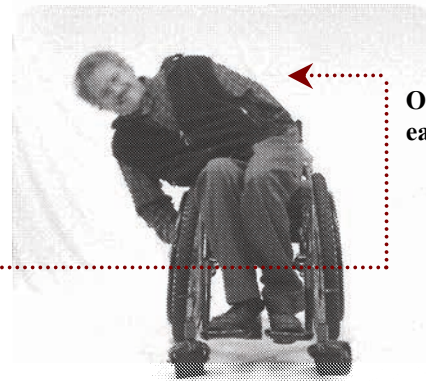

**OR, just lean to each side**



## Leaning Back Weight Shifts

You can relieve pressure if you are able to **lean back** far enough to lift your buttocks up off the seat, as shown.

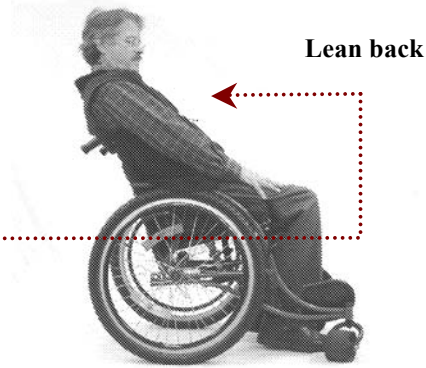

If you can wheelie safely, do so with your back to a chair, bed, or couch. Tip your chair back so your push handles are resting on the support. This will take the weight off your buttocks. When finished, lean forward while you pull back on your wheels to tip your chair upright again.

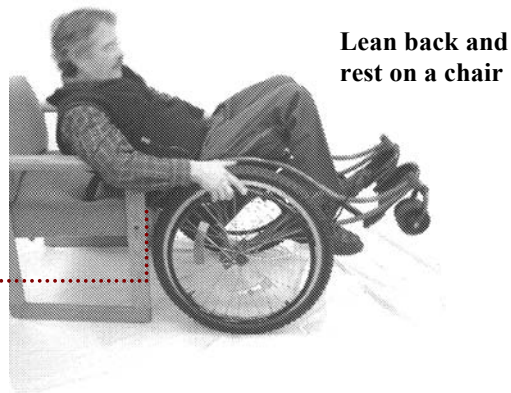

If you can't wheelie, **have someone help you tip your chair back** onto a chair, bed, or sofa. The easiest way is for a helper to sit on the chair/bed/sofa and tip you back until your push handles are resting on the helper's lap.

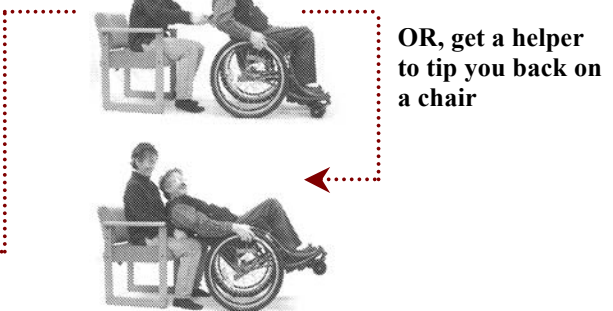



## Moving Around

On flat, smooth ground the best way to push your chair is by using the push rims. If you need more power on hills, ramps, or uneven ground, you can push on the tires or on the tires and push rims together. Experiment with other techniques as you get used to your RoughRider.

### Pushing Forward

1.



1. Grab the push rims with your thumbs along the inside top edge of the push rim, with your fingers wrapping around the push rim from the outside.

2.



2. If you can't grasp the push rims, you can push against them with the heels of your hands. Pushing partly on the tires can help.

Gloves can protect your hands and improve your grip. You can also wrap inner tubes around the push rims for better grip. Rubber band material made for slingshots also provides good grip. If you don't have gloves, you can try wrapping cloth, strong tape or a piece of inner tube around the palm of your hand. This may help you get a better grip making it easier to push the chair.

### Pushing Uphill

**When going up a slope**, you may roll backward when you take your hands off the push rims to take another stroke. To avoid rolling backward, you can **alternate hands**, so that you are always holding one push rim while your other hand is moving back for another stroke. You should also be **leaning forward** when you are going uphill.

Sometimes it is easier to climb a hill by **pushing backward**. Another technique (especially useful on steep slopes) is to **traverse the slope**, pushing your RoughRider across the slope at an angle rather than straight up.

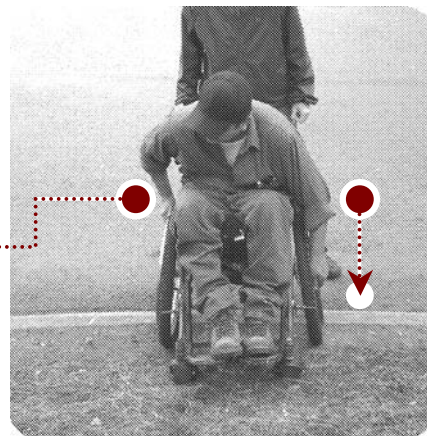



## Transfers: Getting in and out of your RoughRider™

Practice to figure out the best way for you to get in and out of your RoughRider. These are just suggestions for how it might work. While you are learning, you should always have a helper nearby. Practice on a soft surface to avoid injuring yourself if you fall.

### The basics

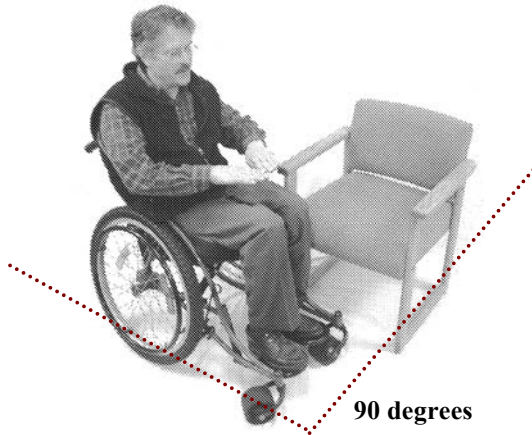

For most people, it is best to have the **wheelchair at a 90 degree angle** to whatever surface you are transferring to or from.

**Lock your wheels** before attempting to transfer. This will keep the wheelchair from moving during your transfer so you won't fall.

If you are able to use your legs to support some of your weight, or if someone is helping you to transfer, you may want to fold your **footrests out of the way**. If you are not able to use your legs, you might want to leave your footrests in place to help support your feet during the transfer.

## Transferring out of your RoughRider

### 1. Figure out where you want your legs to be.

If you can use your legs to hold some of your weight, you will probably want to keep them in front of and underneath you so you can stand up and turn in the direction you need to go.

If you can't use your legs to hold some of your weight, you might want to **move your feet over** so they are in front of where you are transferring to so you won't have to drag them when you move your body.

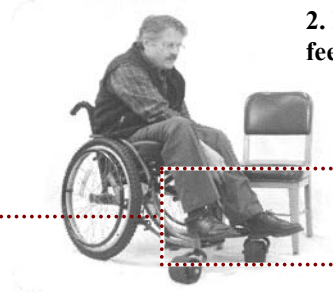

### 2. Move your feet first.

Push up with your hands/arms (push against the wheel, the side-frame or the seat cushion) to lift your buttocks and **move yourself forward** to the edge of your seat.



### 3. Scoot yourself forward to the edge of the seat.

**Get your hands set:** Put one hand on the far edge of the seat you are moving TO. Keep your other hand on the wheelchair you are moving FROM.



### 4. Get your hands set

Using both hands to lift your body up, **swing yourself over your wheel** and onto the other chair.

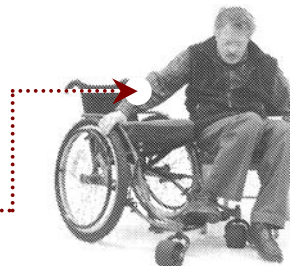

### 5. Lift up and swing over

If you land in a bad position, **readjust yourself**.



### 6. Readjust

## Transferring into your RoughRider



**1. Adjust your legs**



**2. Get your hands set**



**3. Lean forward, lift up and swing over**



**4. Readjust**

## Transferring from your RoughRider to the floor

It is easiest to transfer to or from the floor if you have a support other than your chair to hold onto, such as another chair, bench, step, or bed. Be sure to lock your wheels.

### 1. Get set



Put your chair across from the support with enough room for your body to fit between your chair and the support. Put one hand on the support surface. Put the other hand on your RoughRider cushion, side frame or wheel to push up and off.

### 2. Push Up and move forward



Push up with your hands to lift your buttocks off your wheelchair seat and move yourself towards the edge of your wheelchair seat.

### 3. Lower yourself



Keep supporting yourself with your hands as you lower yourself towards the footrests.

### 4. Move onto the floor



Once you are sitting on the footrests, you can move your buttocks off the footrests and onto the floor.

## Transferring to your RoughRider from the floor

### 1. Get set



Lock your wheels and put your RoughRider next to the support, with enough room between them for your body.

### 2. Get onto footrests



Lean forward and lift your buttocks up by either pushing down on the seat as shown in the picture or by pulling up using the support surface or the backrest tubes of the wheelchair until you are sitting on the footrests.

### 3. Push up



Lean forward and push as shown in the picture or pull on both the support surface and your RoughRider seat or frame to lift yourself up to the seat.

### 4. Slide into your seat



### 5. And adjust your position.





## Traveling with your RoughRider™

### Folding the RoughRider

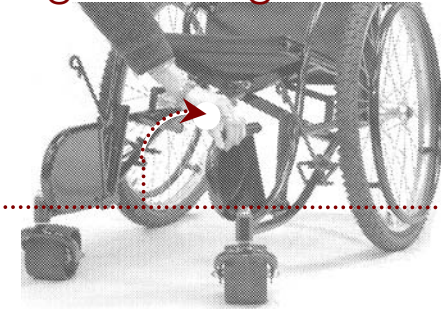

1. Flip the footrests up against the side frames.

2. Pull up on the seat fabric until the chair sides come together.

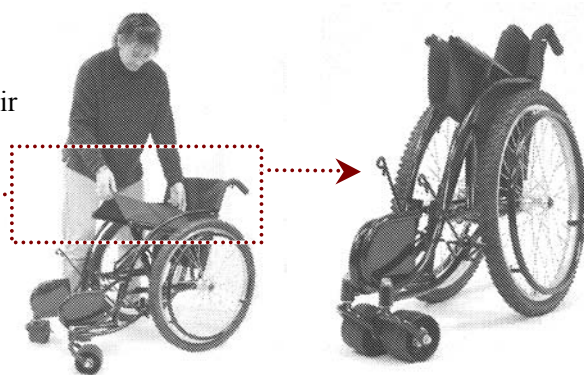

3. It may be helpful to have a piece of rope or cord, an old inner tube, a strap, a strip of cloth, or an elastic shock cord to tie around the side frames to hold them together so the chair will stay folded when it is picked up.

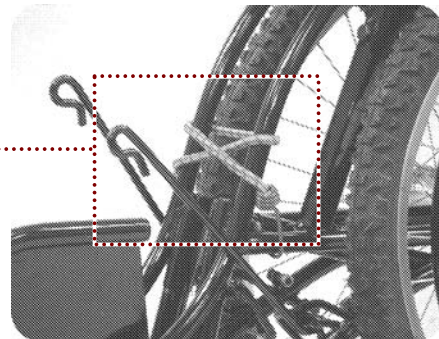

## Riding Public Transportation / Buses



**How to ride:** The type of bus will determine how you ride the bus. To get on the bus, enlist two or more helpers to carry you on board OR drag yourself up the stairs. Your chair can be put in the back of the bus or on the roof of the bus. Even if it is possible to ride the bus in your chair, it is better to sit in the bus seat if you can because it is usually safer. Keep your chair cushion with you at all times to prevent loss.

*A wheelchair rider in Nicaragua gets three helpers to lift her and her RoughRider in through the back of the bus. She has to tell them what part of her chair they should grip to pick her up: “The push handles and side frame. Not by the rear wheels or I’ll end up on my head!”*



“Wheelchair riders always have **the right** to use public transportation. We also have **the responsibility** to help make public transport more accessible. The more we ride, as difficult as it may be, the sooner public transportation will be truly accessible.”

-Ralf Hotchkiss

For information about how to help make buses and transportation systems more accessible, contact:

**Access Exchange International**  
[www.globalride-sf.org](http://www.globalride-sf.org)  
 112 San Pablo Avenue  
 San Francisco, CA 94127-1536 USA  
 (415) 661-6355





## Maintenance and Repair

### IMPORTANT

Routine maintenance can:

- Prevent breakdowns and excessive wear making your chair last longer, go farther, and cost less to repair.
- Prevent injuries or long term damage to your muscles that result from sudden failures.
- Make your chair more comfortable and easier to use.

Some basic maintenance and repairs are explained in this section so that you will be able to keep your RoughRider rolling as long as possible.

A bicycle mechanic may be able to help you with both maintenance and repair if needed. It is a good idea to get to know a good mechanic who is close to where you live. Explain to the mechanic how you use your wheelchair, and use the information in this manual to help your mechanic understand how a wheelchair works.

After reading this section of the manual it is a good idea to discuss anything that is not clear with the manufacturer, distributor, or an experienced Whirlwind RoughRider user. They should be able to show you how to perform different maintenance and repair tasks.

**In an emergency situation, you may be able to:**



- Drive the wheelchair with a flat or completely missing tire by **leaning your weight away from the missing/flat tire** (though this will quickly damage the wheel rim).
- Drive the wheelchair without one of the front casters by leaning your weight away from the missing wheel.

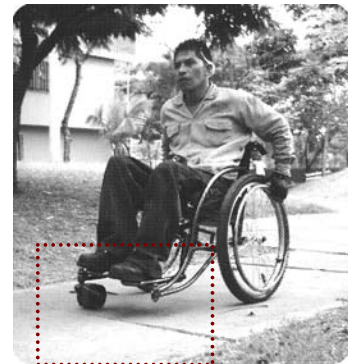

It is always a good idea to carry an inner **tube puncture repair kit** and a bicycle pump with you in case of emergencies. Whenever possible, you should also carry an adjustable wrench and a screwdriver. **You should also keep spare parts and tools available** in your home for easy access. Spare parts should include bearings, tubes, nuts, and cushions. Tools you should have in your home include a second wrench, a small hammer, a spoke wrench, and a knife.



## Maintenance Schedule

Routine maintenance can help prevent breakdowns and excessive wear. It will make your chair last longer. Here is a calendar showing when to do basic maintenance tasks. For how to do the specific maintenance go to the corresponding detailed descriptions.

RoughRider part	What to do	Complete description on page
<b>WEEKLY</b>		
Cushion	Check for cleanliness or breakdown of foam and structure. Clean when needed. <i>Check your skin condition daily.</i>	Page 33
Tire Pressure	Check tire pressure. Add air when needed.	Page 44
<b>MONTHLY</b>		
Bearings	Basic Bearing Maintenance: Lubricate bearings in caster wheels, caster barrels, and rear wheels with oil* (see notes on recommended oil to use).	Page 34
Upholstery	Check for damage, wear and dirt. Clean or replace as necessary.	Page 38
<b>EVERY 2 MONTHS</b>		
<b>Lubricate</b> Wheel Locks with oil* (see notes on recommended oil to use).		Page 43
Wheel locks	Adjust to correct position. Lubricate moving parts. Tighten nuts. Every other month OR when wheel locks are not holding chair in position OR when wheel locks become difficult to lock.	Page 40
Spokes	Inspect and tighten spokes to true the wheels. Every other month OR when spokes are broken or loose OR if wheels wobble when spinning.	Page 41
Cleaning and Routine Inspection	Clean, lubricate, and inspect your RoughRider for damage every 2 – 3 months if living in rough rural environments where you are riding in dirt rather than on paved roads; 2 - 3 times / year otherwise.	Page 46 - 47
Nuts and Bolts	Tighten nuts and bolts. During Cleaning and Routine Inspections.	Page 48
<b>2 – 3 TIMES / YEAR</b>		
<b>Lubricate</b> footrest pivot, folding stabilizer pivots, spoke threads, X-brace pivot, and pivot tube with oil* (see notes on recommended oil to use).		Page 43
Bearings	Thorough Bearing Maintenance: Clean and repack with grease* (see notes on recommended grease to use). 2 – 3 times / year if living in rough rural environments; 1 time / year otherwise.	Page 35



## Bearings

Maintaining your bearings will make them last longer and will help your chair roll more easily.

### How to Make Your New Bearings Last Longer



- Pack bearings with as much bearing grease as possible. See Thorough Bearing Maintenance section for how to pack bearings with grease.
- Install bearings with a washer made of felt on outer sides of bearings under a steel washer to prevent dust and dirt from entering bearing.

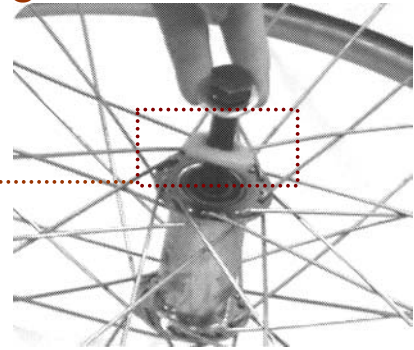

**\*Recommended oil for basic maintenance:** Heavier oil is better. The best oil to use is 90 or 140 weight gear oil; the next best is 20 weight electric motor oil.

#### Do NOT use:

- Automotive engine oil. The detergent in automotive engine oil will mix with water.
- Common penetrating household lubricants and degreasers like WD40 should **not** be used. Use of penetrating lubricants can damage the seals and remove grease. Bearing life will be significantly shortened if you use your chair with ungreased bearings. Penetrating oils should only be used for cleaning. After cleaning with a penetrating lubricant, repack the bearing with grease (see Thorough Maintenance section).
- Light sewing machine or household oils. These oils are too light and will not stay in the bearing for long.

## Maintaining your Bearings

**Basic Maintenance** (every month OR when you feel your chair slowing down and you don't have time to do more):

- Lubricate your **caster wheel**, **caster barrel**, and **rear wheel** bearings with oil\*.

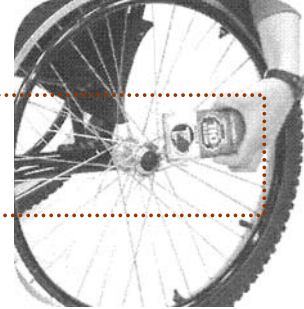

**\*Recommended bearing grease for thorough maintenance:** One of the best types of bearing grease is water resistant boat trailer ball bearing grease. Automobile ball bearing grease is very good, but is less water resistant.

### Thorough maintenance for rear hub and caster barrel bearings

(2-3 times / year if in rough environment; 1 time / year otherwise)

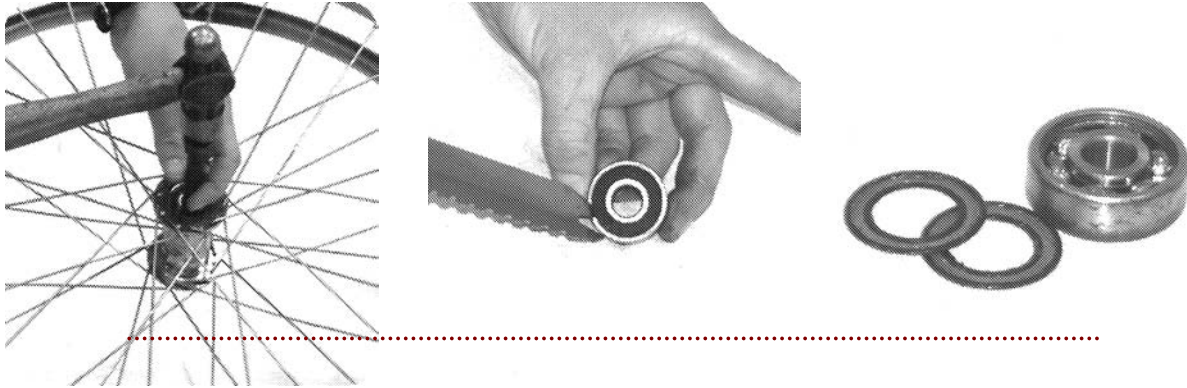

- To remove the bearings from the hub, remove the wheel from the wheelchair and take the axle bolt out.
- Reinsert the axle bolt at an angle so that the tip of the bolt contacts the inside face (inner race) of the bottom bearing (see above left picture). Gently tap on the head of the axle bolt as you move the bolt's tip around the hole of the bearing until the bearing falls out. Hammer lightly; do NOT hammer with force. Turn the wheel over and remove the other bearing. The same process can be used to remove the bearings from the caster barrel. If the bearings will not come out, put some light oil (not penetrating oil) around the bearings and try again later.
- Once the bearings are removed carefully pop the seals off with the tip of a knife.
- Clean all parts with kerosene making sure to get all of the dirt out. A brush such as a toothbrush can also be helpful.
- Allow to dry; then repack/reassemble bearings with as much bearing grease as possible.
- Replace the seals.

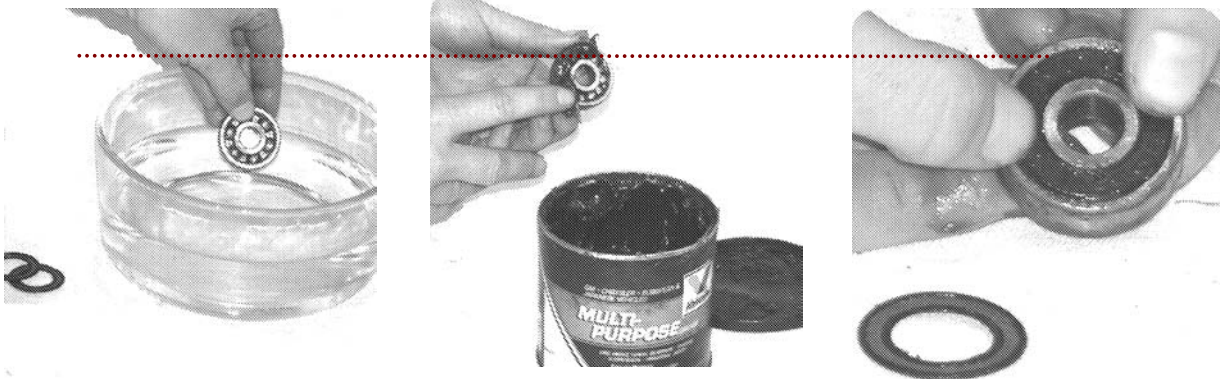

**Thorough maintenance for front wheel bearings**

(2-3 times / year if in rough environment; 1 time / year otherwise)

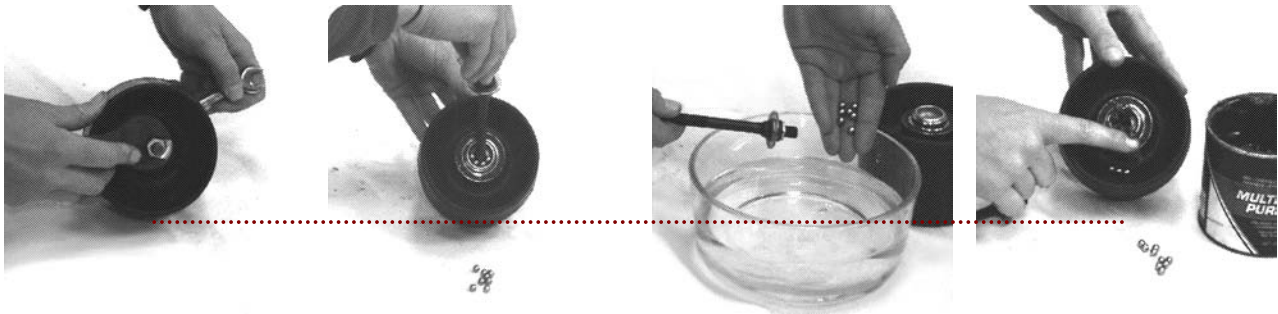
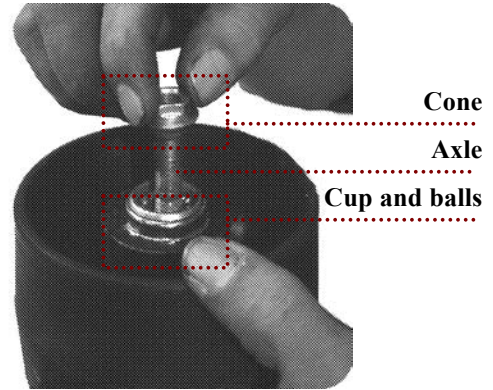

- If caster fork has slots: Take the wheel out of the caster fork by loosening nuts until the wheel drops out of the fork. If the caster fork does not have slots: Take the wheel out of the caster fork by loosening nuts and screwing cones toward one side until axle is off center enough to pry out of fork.
- To disassemble bearings, unscrew the cones outward/away from wheel until balls fall out.
- Clean all parts with kerosene.
- Allow to dry; then replace the balls and reassemble bearings with as much bearing grease as possible. Dipping the balls in grease will hold them in place and make assembly easier.

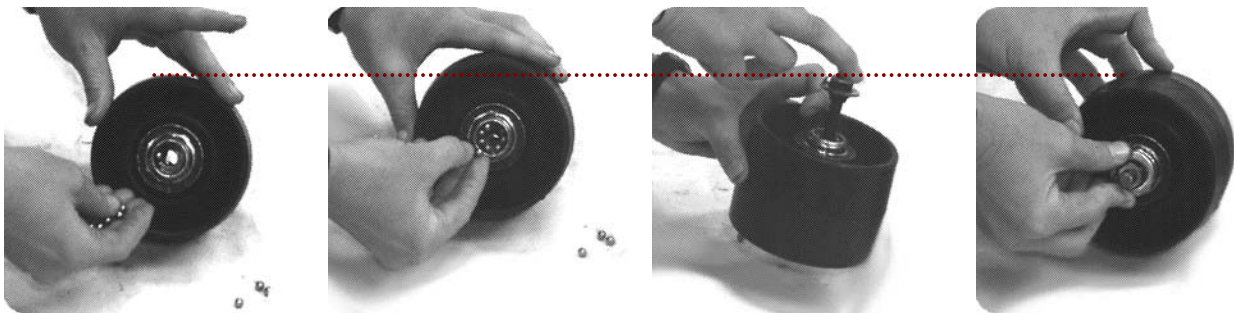

## Repair or Replace your Bearings

If after being cleaned and repacked the bearings still do not move easily, you will have to replace either the balls or the whole bearing.

**Sealed bearings** in rear wheel hub and caster barrel: If the bearing still does not move easily after being thoroughly cleaned, replace the entire bearing.



**Cone**



**Cup**

**Front wheel bearings** (bicycle bearings): Replace balls if broken or cracked. If the wheel still does not move easily, **inspect cup and cone for damage**. If the surfaces that the balls roll on are obviously rough, these parts should be replaced. If you need help, a bicycle mechanic should be able to do this.



## Upholstery

### IMPORTANT

Upholstery that is worn unevenly or otherwise damaged can be dangerous as it:

- Can cause uneven pressure on your buttocks or legs.
- Can cause you to sit in an uncomfortable position.
- Can rip suddenly and cause you to fall out of the chair.

By inspecting your upholstery regularly you will know when you need to replace your upholstery. Your upholstery will not last as long as the wheelchair and will have to be replaced over time. Make sure all bolts or screws that hold the upholstery in place are there. Replace any missing bolts to make your upholstery last longer and prevent injury from upholstery failure.

It is important to **keep the upholstery clean and dry** because dirt and moisture (sweat, food, drink, dust, mud, or other substances) can cause the upholstery to wear more quickly or rot. Soil (dust/mud/etc.) can contain abrasive materials which may wear the upholstery away and cause it to wear out much more quickly than if it is kept clean. Moisture can cause the upholstery to rot and the fasteners, which hold the upholstery to the frame, to rust. If the upholstery stays wet it can also stretch.

## Maintaining your Upholstery

**Inspect your upholstery** 1 time / month and look for tears, wear, dirt, or any metal parts sticking through the upholstery that could injure you.

You can **clean your upholstery** by removing it from the chair. Wash the upholstery with mild soap and water. Allow the upholstery to **dry thoroughly** before putting the fabric back on the wheelchair. You can also wipe the upholstery down without removing it from the chair. If you wipe the upholstery, be careful not to get the seat screws and other movable parts of the wheelchair wet.





## Repair or Replace your Upholstery

**Upholstery stretches:** The upholstery should be tight when the chair is open. As fabric stretches over time the RoughRider's seat will get wider. Your RoughRider should not get significantly wider than its intended width. If your seat width is wider, you will have to work harder to push your RoughRider since you will have to reach farther out to grab the push rims. If your seat is more than 40mm (1.6 in.) wider than the original seat width you may be able to adjust your seat fabric back to the original size by sewing new seams along the edges to make it narrower or by moving the holes inward. Use your measurements when you originally received the chair to get the correct width and height of the seat. If you are not able to correct your seat width it may be time to replace your seat upholstery.

**Holes in the upholstery:** Avoid riding in a wheelchair that has holes or tears in the seat because sitting on an uneven surface can cause bad posture and may increase the pressure on your buttocks. If there are any holes or tears in your seat or seat back, either repair them or replace your seat upholstery. If the holes are not too big, it should be possible to patch the holes. It is best to use the same fabric as the original upholstery. If the holes are very large, or the upholstery is so worn it cannot be patched (many holes, very faded, thinning, etc) you will probably need to replace it.



## Wheel Locks

### WARNING

Loose wheel locks or wheel locks that aren't adjusted correctly may not fully lock the wheels and can cause you to fall while getting into or out of your chair, resulting in injury to you or damage to the chair.

### Maintaining your Wheel Locks

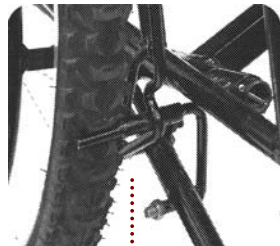
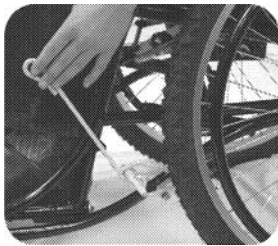

It should be very difficult to move your wheels when they are locked.

- Check that the wheel locks are adjusted so that they push in slightly on the tire (about ½ cm or 3/16 in.).
- Check that the nuts and bolts are all there and sufficiently tight.
- Check your tire pressure. If your tires are under-inflated your brakes may slip.

To adjust your wheel locks:

- Make sure that the wheels are sufficiently inflated before adjusting.
- Loosen the bolt that holds the tube clamp tight around the side frame tube.
- Move the wheel lock into a functional locking position and retighten the clamp.

If the wheel locks are hard to operate and push too much into the tires, the wheel locks are too close to the wheel. Move them further away from the center of the wheel.

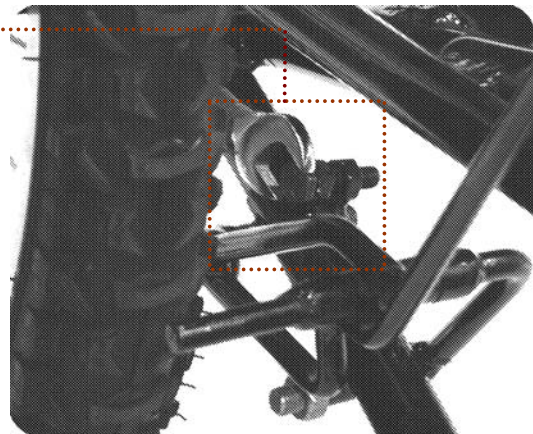



## Spokes

Loose or broken spokes can cause a wheel rim to bend. A few loose spokes will not necessarily make riding more difficult; however, they may allow a wheel to collapse when going over a curb or a big bump and can also make other spokes break more easily since there will be more tension on them.

### Maintaining your Spokes

To **check for and tighten loose spokes**, go around the wheel squeezing pairs of spokes together with your fingers.

- If a spoke gives when you pull it gently, it needs to be tightened. Tighten loose spokes at the nipple, where they meet the wheel rim, with a spoke wrench, turning each one a little bit at a time.
- If a spoke does not give at all, it may be too tight. Loosen it by turning the spoke nipple the opposite direction.

Another method for checking for loose spokes is to pluck each spoke with your fingernails. If a spoke makes a sound noticeably lower in pitch than the other spokes, it should be tightened. If a spoke makes a sound much higher in pitch than the other spokes, it may be too tight and should be loosened.

To **check the wheel's alignment**, lift the wheel off the ground and spin it while you look across it from one edge. Your wheel should turn freely and smoothly with no wobble. You can also use a stationary object (like your frame) to see if the wheel stays the same distance away while spinning. If the rim is bending or wobbling to one side of the wheel, tighten spokes on the other side of the bent part of the rim to center the rim. A bicycle mechanic will be able to do this if you need help.

To make sure your rear axle is tight, push sideways on the wheel rim. The wheel should not wobble around the axle. The wheels should not touch the back tubes or rub against your clothes. Tighten the nut(s) on your rear axle to eliminate the wobble. Make sure the wheel rotates easily; if the wheel does not rotate easily the nut is too tight.

You may be able to check the wheel's alignment while seated in your chair by taking your weight off the wheel and suspending your wheel in air while spinning it.



## Replacing Broken Spokes

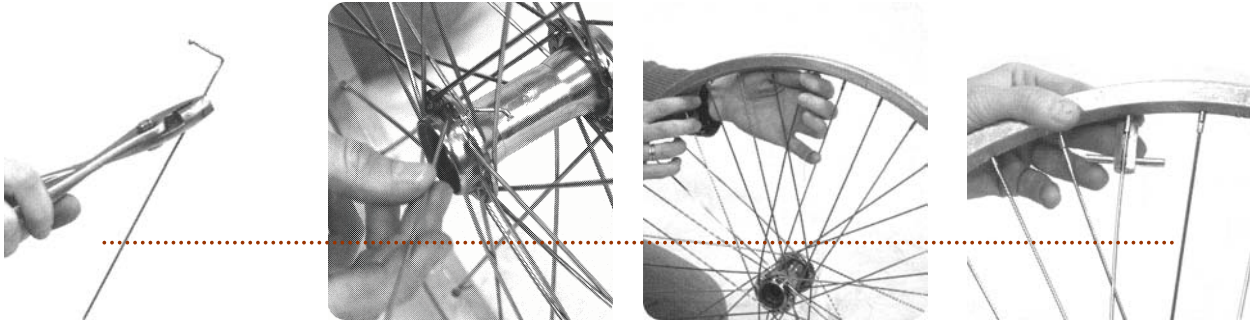

- **Remove tire and tube.**
- **Remove broken spoke** and insert the new spoke in the same direction as the broken spoke (spokes on the same side of the hub should alternate directions).
- **Weave the new spoke** in the same pattern as the other spokes (look very carefully at the existing pattern to make sure you are doing it the same way).
- **Insert** the threaded end of the spoke through the same hole in the rim that the broken spoke went through. Thread the small end of the nipple through the hole in the rim and screw it onto the end of the spoke.
- If a spoke of the same length is not available a longer spoke can be used. Make a sharp bend in the long spoke at the non-threaded end to the length needed. The bend in the spoke will hook through the hole in the hub (see the above left two pictures). As you begin to tighten the nipple, bend the hook end of the spoke back against the main shaft of the spoke.
- **Tighten** the new spoke and adjust as many of the spokes around it as necessary to align the wheel.
- A bicycle mechanic will be able to do this if you need help.



## Lubricating your RoughRider™

Consistently lubricating your RoughRider will keep all the moving parts operating smoothly and efficiently. Use medium- to heavy-weight oil. Do not use common penetrating lubricants like WD40 because they can damage the seals and remove grease. Bearing life will be significantly shortened if you use your chair with ungreased bearings. Penetrating oils should only be used for cleaning. After cleaning with kerosene or a penetrating lubricant, repack the bearing with grease (see Maintaining Your Bearings section).

**Apply oil to each of the following parts** one drop at a time until the area is saturated and the part moves smoothly.



**X-brace pivot tubes, center pivot, and folding stabilizer pivots**

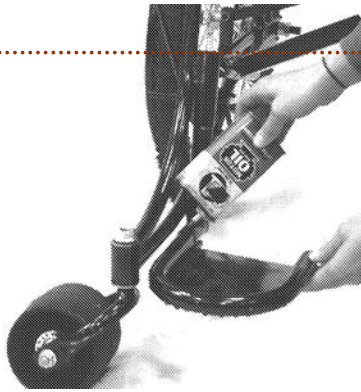

**Footrest pivot tubes**

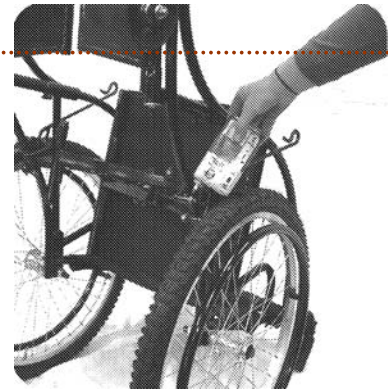

**Wheel locks**

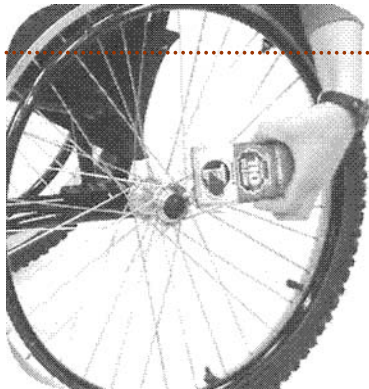

**Bearings: Rear wheel, caster wheel, and caster barrel**



**Spokes**  
Put a tiny drop on each spoke where it enters the nipple.



**Seat tubes and side frame**  
When chair is folded, rub candle wax onto the contact surfaces between seat tubes and side frame. The wax will make folding easier and prevent the paint scraping off.



## Tires



### Maintaining the correct tire pressure:

- Increases the life of the tires, saving you money;
- Decreases the rolling resistance and saves you energy;
- Keeps your wheel locks working properly.

**Check tire pressure** by pressing with your thumb across the width of the tire. For average pressure you should be able to barely depress the tire (about 5mm (3/16 in.)

The correct tire pressure will be different depending on different conditions. Higher pressure (harder tires) helps the chair move faster, but is less comfortable, is harder to push on uneven terrain, and can be slippery on wet pavement. Lower pressure (softer tires) is more comfortable on uneven ground but the tire is more vulnerable to getting flats and can put more strain on your arms and shoulders. If the tire pressure is not the same in both wheels, your RoughRider will turn toward the side of the lower pressure tire.

## Tool Kit for Tire Repair

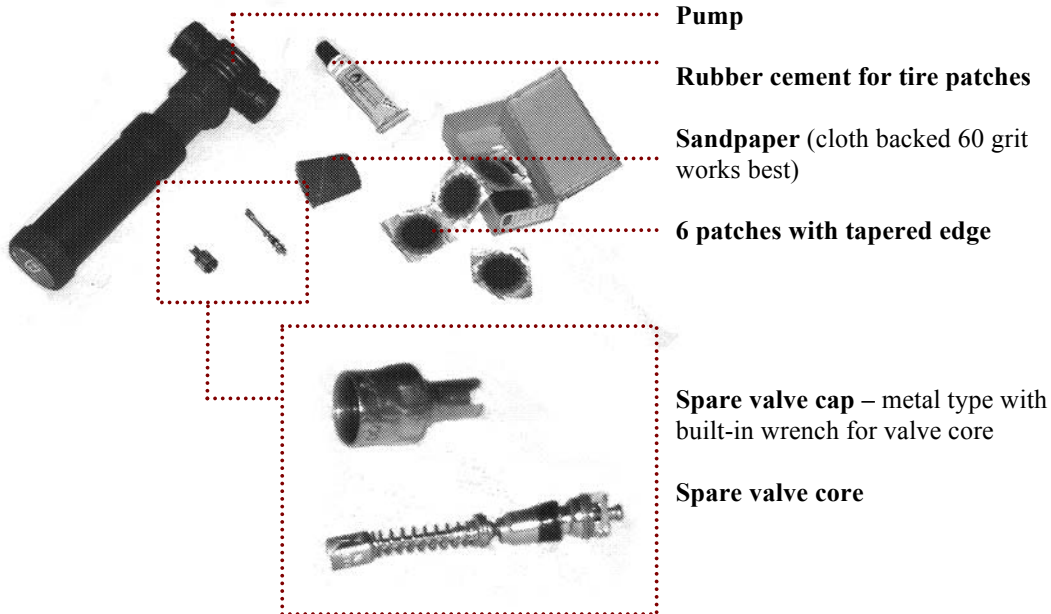

## Repairing or Replacing Tires and Tubes

When tire tread gets very worn, or the tire is brittle or cracked, it is more likely to go flat, so be ready to replace it.



If tire is not damaged and only the tube needs repairing:

- **Remove tire** by gently prying it outside the rim using a tire tool or a screwdriver with the edges filed smooth (or the ends of spoon handles like the picture above). Pull tube out of tire.
- Carefully inspect inside of the tire for the cause of the puncture. The cause of the puncture may be screws, thorns, glass, or other sharp material that may still be stuck in the tire tread and will puncture the tire again if it is not removed.
- **Find hole** in tube by pumping halfway full and squeezing it. You may be able to find the hole by the sound of escaping air. If not, put the tube under water. Squeeze the tube and watch for bubbles escaping from the hole. Another way to do this is to rub soapy water on the tube and watch for bubbles forming in the soap.
- **Mark** around the hole with a pen or pencil.
- Let any remaining air out of the tire.
- To **repair tube, roughen the surface** around the hole (about 25 cm (1 in.)) by rubbing the tube with sandpaper. Make sure the surface is completely clean and dry.
- If there is glue, **apply glue** and wait about 30 seconds for glue to get tacky.
- Press on **patch** and let dry. For temporary repairs to torn tires wrap a strip of canvas around inner tube 2-3 times.
- **Replace tube** and tire and re-inflate to desired pressure.

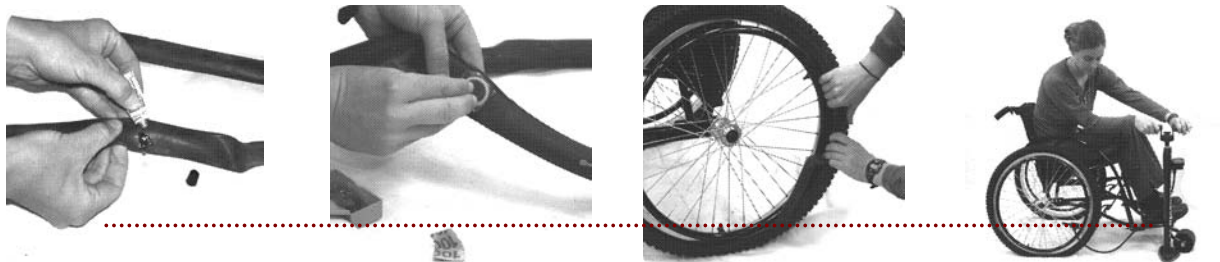



## Cleaning your RoughRider™

Keeping the chair clean and dry helps keep the metal parts from rusting and the upholstery from rotting. Cleaning also prevents damage caused by dirt or sand scraping against the chair's moving parts.

**Clean the frame and upholstery** as needed using water with a little mild soap, making sure to rinse and dry it completely afterward. Pay special attention to all moving parts, such as the axles, the caster barrels, pivots where the chair folds, and areas where the upholstery is fastened to the frame; dirt can be especially damaging to these areas.



After each cleaning, and only after the chair is completely dry, **apply medium- to heavy-weight oil to all moving parts** on the chair (x-brace pivots, pivot tubes at the bottom of x-brace, folding stabilizer pivots, wheel lock pivots, and footrest pivots) to prevent rusting and to keep the moving parts moving smoothly.

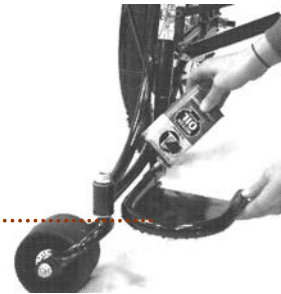





## Routine Inspections

### IMPORTANT

Inspection of the chair's frame for damage that needs repair is a good thing to do while you are cleaning it. If tubes are bent, the wheelchair may be out of alignment and will not roll smoothly or in a straight line. Cracks in the wheelchair's tubes or joints are indications of where the wheelchair may break completely and should be repaired as soon as possible.

To **do routine inspections**, look over your RoughRider while not sitting in it to make sure there are no holes in the upholstery, cracks in the welds, bends in the tubes, loose nuts or bolts, bent axles, uneven footrests, or loose handgrips. If you find major structural problems like cracks or bends, you should have your RoughRider repaired as soon as possible by a capable technical professional (for example a bicycle mechanic or auto repair technician) to prevent major failure.

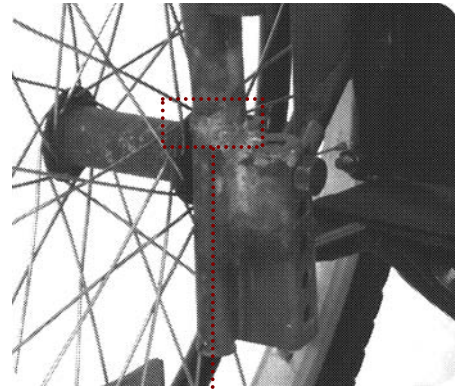

**This frame cracked after years of use and was then repaired and reinforced.**



## Nuts and Bolts

Although your RoughRider has been designed with a minimum number of nuts and bolts, over time and miles of travel, your RoughRider will experience vibrations and torque that can cause the nuts and bolts to loosen. Loose fasteners allow unwanted extra movement in the chair and this movement makes pushing your chair more difficult. Loose fasteners also make other parts, like the brakes, hard to use. Tightening loose nuts and bolts will prevent parts from getting lost or broken and will help your RoughRider roll more easily.

### Tightening Nuts and Bolts

Inspect your RoughRider for loose nuts and bolts. If loose, tighten them with a wrench. The center pivot bolt of the X-brace should **not** be tight but the locknut used to keep the bolt from falling out should be very secure and hard to turn. You should be able to hold one caster wheel down and lift the other 2 cm (3/4 in.) above the ground with little effort.

Lock nuts or split nuts should be repaired if you notice they are coming loose. See the Split Nut repair section for a solution.

You should not have to use too much force to tighten a nut. If tightening is difficult, then the nut may be cross-threaded on the bolt. If you tighten a cross-threaded nut, you can ruin the threads of the bolt and that might make it difficult to remove the nut later.

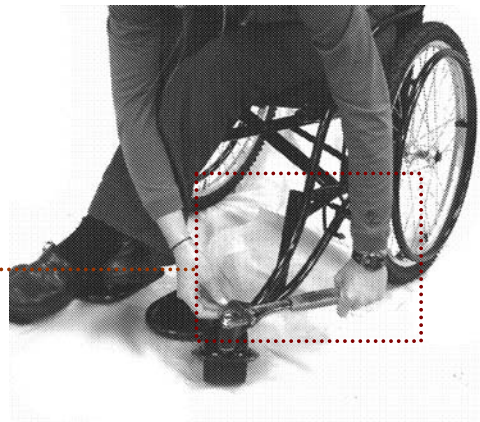

## Repairing or Replacing Nuts and Bolts

If a bolt cannot be repaired it should be replaced, but some repairs are possible:

**Rounded bolt head or nut?** File two opposite sides of the bolt head or nut until they are flat enough to get a good grip with a wrench. If the bolt or nut will still not turn then the nut may be rusty.

**Rusted nut?** Apply a mixture of **light oil and kerosene** so that it can flow onto the threads of the bolt and nut, then wait. Try to loosen the nut periodically over the next few hours. If it is not possible to loosen the nut, **cut the head of the bolt off** with a hacksaw, remove the bolt, and replace it.

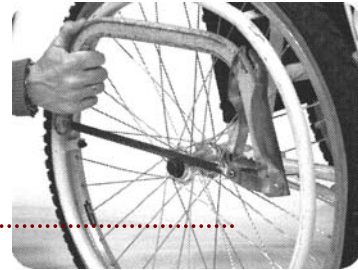
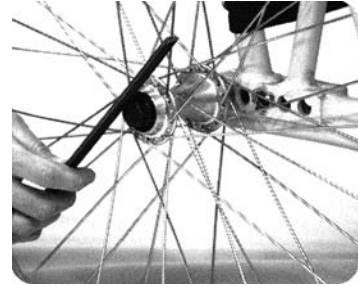

Your RoughRider uses **lock nuts** in multiple locations so they do not come loose from the vibrations that happen during normal use. A lock nut is harder to turn than a regular nut and should not come loose by itself. Your chair will come with either standard commercial “nylocks” or with Whirlwind split nuts. A nylock is a nut with a nylon ring on the inside. If the nylock is easy to turn it has lost most of its locking capacity and should be replaced. A Whirlwind split nut is a lock nut that can be easily made with the correct size standard nut and basic tools (hacksaw and clamp/vise). A worn out nylock can be replaced with a Whirlwind split nut.

### To make a split nut:

- Firmly grip the nut on the top and bottom faces (as shown in bottom center photo).
- With your hacksaw blade slightly off center, cut halfway through the nut.
- Squeeze the nut in a vise or clamp or smash it with a hammer to close the slit (as shown in bottom right photo).
- When putting the nut on your RoughRider place it so the wider slice screws on first.

If the Whirlwind split nut becomes easy to turn it may be able to be repaired.

### To repair a Split nut:

- Check that the slit is cut half way through one side of the nut. If it is cut less than half way through, use a hacksaw to complete the cut to half way.
- Squeeze the nut in a vise or smash it with a hammer to ensure the slit is closed.

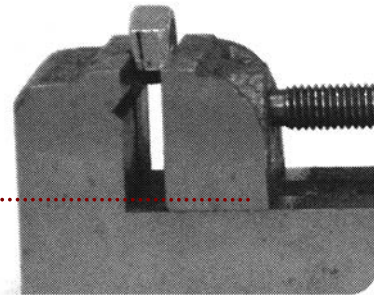
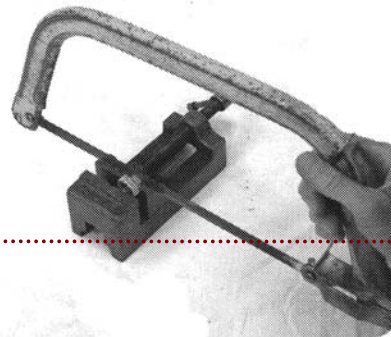



## Footrests

Footrests must be at the correct height to maintain a good sitting position and pressure relief.

Check to make sure that your footrests are at the proper height for your best sitting posture. You might want to mark the frame where they should be to make it easy to check their alignment. Your feet should rest lightly on the footrests when you are sitting in your best position in the seat and you should have even pressure over the entire surface of your seat.

If your **footrests are too low**, you will tend to slide forward in your seat to keep your feet on the footrests. Sliding forward in your seat can cause bad posture, make you uncomfortable, and cause pressure sores if you have no sensation in your buttocks.

If the **footrests are too high** there is more pressure on your buttocks which may be uncomfortable and can cause pressure sores.

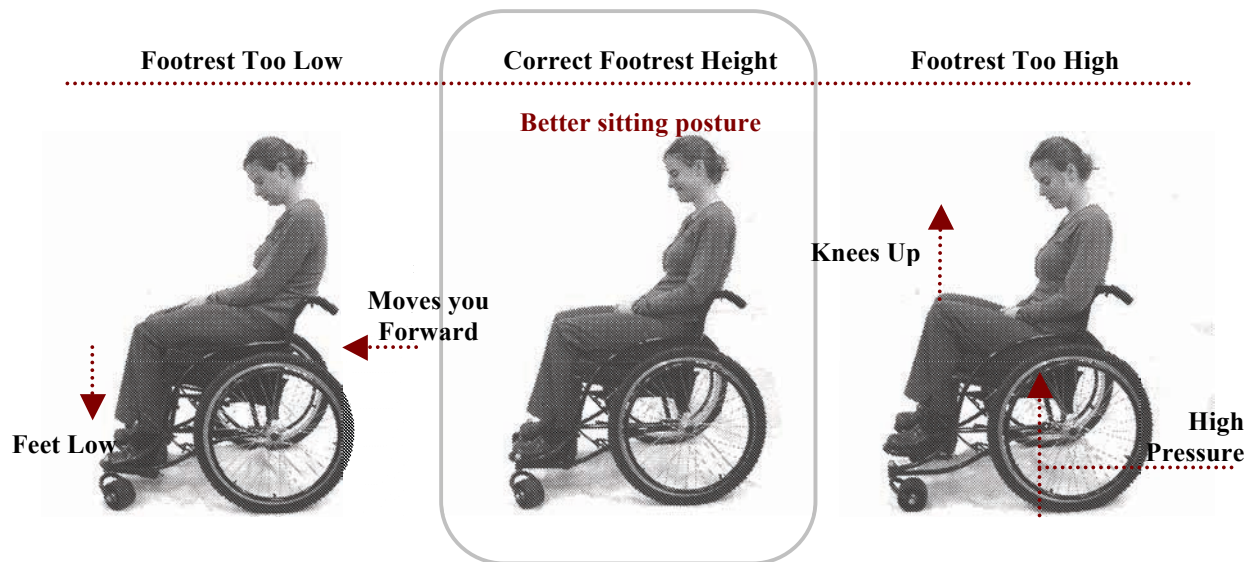

To **adjust the footrest**, loosen the bolt on the footrest clamp tube. Move the footrest to the correct position and tighten.

You will have to adjust your footrests while not in your chair or get someone else to help you.

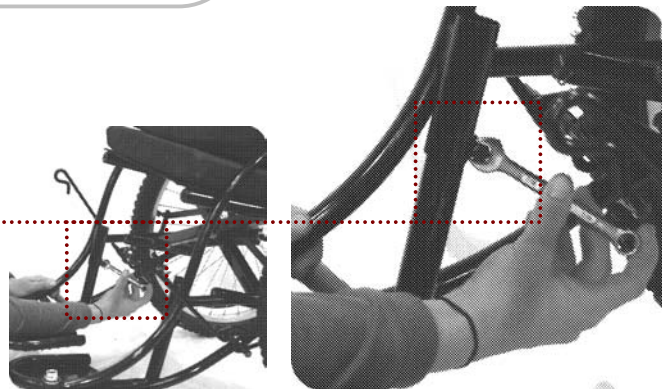



## Handgrips

### CAUTION

Loose handgrips can cause serious injury if they slip off while someone is pulling the chair, especially pulling up stairs or curbs.



Check to make sure your handgrips are tight by pulling on them as if you are trying to remove them.

If you can pull the handgrips off, they must be re-glued using strong glue. A very good glue is heavy duty contact cement that is made especially for installing automobile weather-stripping.

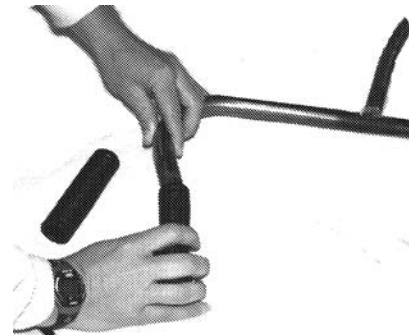

If strong glue cannot be found, remove the handgrips completely and be cautious when lifting the chair by the bare handles.



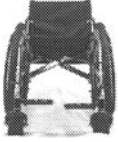

## Troubleshoot: If your RoughRider™ Does Not Roll Straight

If one wheel has more resistance than the others, your chair will turn to the side to which that wheel is attached. This turning occurs because the wheel is rotating slower on that side, as if you were braking or pulling on it. This resistance will also make you work harder when pushing because you will have to compensate for this unevenness.

**Check to see if the chair rolls in a straight line.** Find a flat area with as few bumps as possible. Roll your RoughRider at a medium speed while trying to push equally on each wheel. Let go without shifting your weight and see if your RoughRider drifts to one side. If it does, this is usually the side that is affected by one of the problems below. After trying any of the solutions below, check to see if your chair rolls in a straight line.

**Observe.** Look at the chair on a flat surface and notice what doesn't look straight. Look at the caster barrels, caster wheels, rear wheels, and side frame.

### Uneven Tire Pressure

A chair will turn toward the tire with the lower pressure.

**Solution:** Equalize the pressure in the two tires either by pumping up the lower pressure tire or by releasing some of the pressure in an over inflated tire.

### Dirty or Damaged Bearings

A chair will turn toward the side of the chair where the bearing is sticking (like braking on one side).

**Solution:** Check the bearings in the caster wheel and rear wheel. See Bearings section; Check and clean or replace bearings as appropriate.

### Stuck X-Brace

A chair will turn toward one side if the X-brace pivot does not move easily or is jammed so that one caster wheel is suspended above the ground. You should be able to see if this is the problem if you look at how your 4 wheels contact a flat surface when you are seated in the chair.

**Solution:**

- Loosen X-brace center bolt. The center bolt should not be tight. There should be approximately 0.5 cm between the locknut and the square tube. With a person seated in the chair, you should be able to hold one caster wheel down and lift the other 2 cm (3/4 in.) above the ground with little effort.
- Check to make sure that there is a good locknut (nylock or split nut) to keep the X-brace center bolt from falling out. Another option for a locknut is to use two nuts to make a jam nut. Thread the first nut onto the bolt. Thread the second nut onto the bolt and tighten it firmly against the first nut to create a locked nut.
- Lubricate and manipulate the X-brace to loosen the joint.

## Rear Axle Out of Alignment

A chair will roll with much greater resistance due to the scuffing on the ground caused by one wheel pointing in or out (toe-in or toe-out).

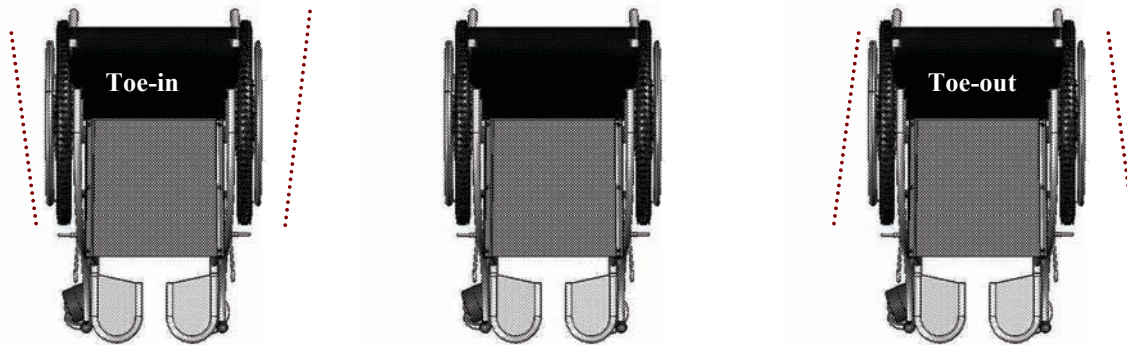

**Solution:** Measure the distance between the rear wheels at their front and rear edges. Pick a point half-way up the wheel (even with the axle) to make the measurement. If the two distances are within 6 mm (1/4 in.) of each other, the wheels are ok.

If the distance of either measurement is more than 6mm (1/4 in.), then, do the following:

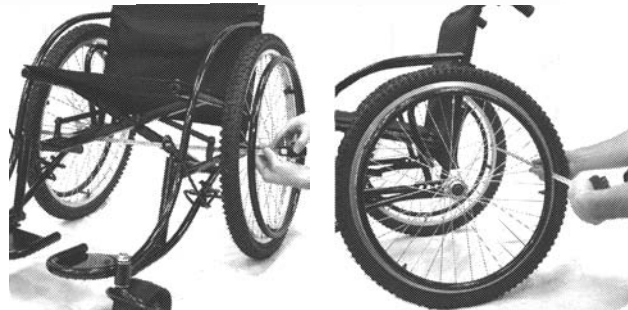

Measuring the distance between the rear wheels at front and back of wheel

- Check to see whether the **axle bolt is bent**. If it is bent, replace it. If the bend is minor, the axle can be straightened by hammering it on an anvil. If it is not bent then,
- Check the **fit of the axle** in the axle block hole. If the axle bolt fits loosely, the axle hole may be deformed. You may have to move your wheels to a different axle position.
- If the axle is straight and fits in the hole but the wheels are still not pointing in the same direction, the **axle block might not be straight**. You may need to bend it back into alignment. Check the angle of the axle block by putting multiple bolts into the block and measuring their angle by referencing a perpendicular surface. Get the help of a mechanic with a very large adjustable wrench; clamp the frame close to the axle block. Check very carefully for cracks in the frame after making any bends. Weld shut and reinforce any cracks.

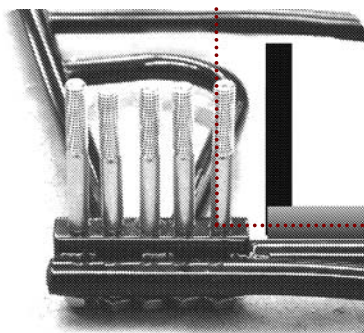

Check angle by referencing to a perpendicular surface

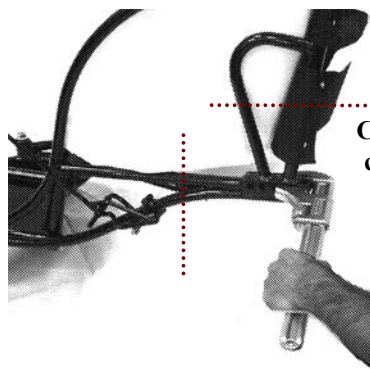

Clamp frame close to axle block

## Bent Caster Barrels

Have someone sit in the chair or put something nearly equal to your weight in the seat, then look to see if the caster barrels are straight by checking whether the barrel and the side frame are parallel with each other and at a right angle to the ground.

If a caster barrel is not vertical, the caster wheel will be pulled in the direction that the barrel is tilted and the chair will turn to that side.

**Solution:** Re-align the caster barrel. Get the help of a mechanic with a very large adjustable wrench to bend the caster barrel so that it is parallel with the side frame and perpendicular to the ground. Check very carefully for cracks in the frame after making any bends. Any cracks must be welded shut and reinforced.

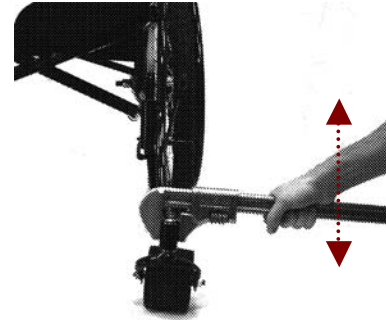

## Caster Wheel Rubs on the Fork

A chair will veer to one side if the caster wheel rubs against the fork; friction will act like a brake on the wheel and your RoughRider will pull to that side.

The caster wheel could be rubbing on the fork for two reasons: the caster fork could be bent or the caster wheel is not centered in the fork.

**The stem of the caster fork is bent** – The chair will veer to one side if the stems of both forks are not precisely at a right angle to the axle of the caster wheel.

**Solution:** If the caster fork is bent at the junction between the fork and the bolt (stem) get the help of a mechanic with a large vise to straighten the fork; after making any bends, check very carefully for cracks in the fork and where the fork and stem meet. The angle between the fork and the stem should be 130 degrees. You can put the caster fork in a vise with the bolt pointing upward. Be careful not to dent the fork by clamping it too tight. You can protect the fork from the jaws of the vise with two scraps of wood or heavy leather. Put a thick-walled tube over the bolt and pull to change the angle of bolt.

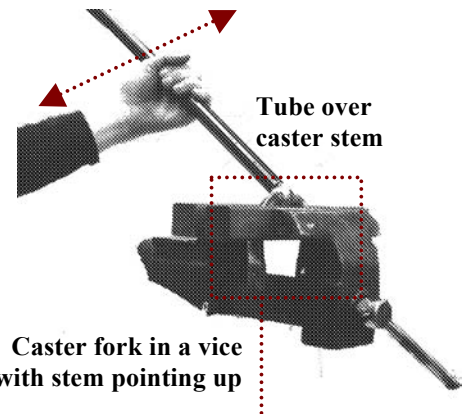

**The caster wheel is not centered in the fork.**

**Solution:** If the caster wheel is not centered on the axle, center it by removing or adding washers. Replace any missing nuts.

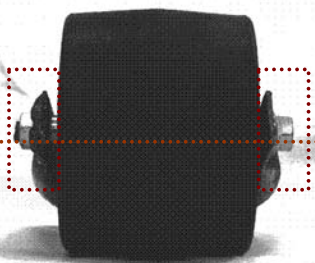

Remove or add  
washers

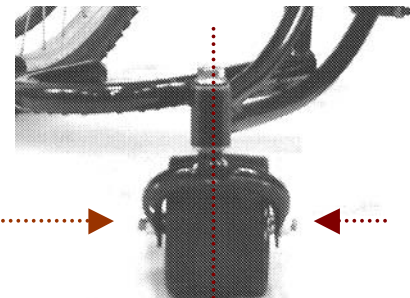

Center wheel  
in fork



## Rear Wheel Rubs on the Side Frame

**Cause 1:** Your RoughRider will pull to one side if the axle bolt is loose. If the axle bolt is loose in the axle block, the weight of the rider on the seat will cause the wheels to lean in at the top. If they lean far enough, the wheel might rub against the side frame, friction will act like a brake on the wheel and cause your RoughRider to turn toward that side.

**Solution:** Tighten the axle bolt. Replace any missing washers or nuts. If the hole in the axle socket has become too large and too loose, move your wheels to a different axle position.

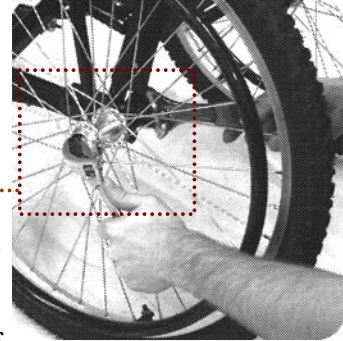

**Cause 2:** The wheel is bent. If the wheel rim is bent, you can usually fix it by adjusting the spokes.

**Solution:** Adjust and tighten the spokes as shown in Spokes section. If the wheel rim is bent a lot, you must straighten it before adjusting the spokes.

**Cause 3:** The axle block is bent relative to the frame.

**Solution:** Re-align axle block as shown in Rear Axle is Out of Alignment section.

## Frame is Misaligned

If one of the side frames leans inward while you are riding the chair, the chair may turn away from that side. The side frame of the chair leans inward when the ends of the seat tube on the same side of the chair are bent inward.

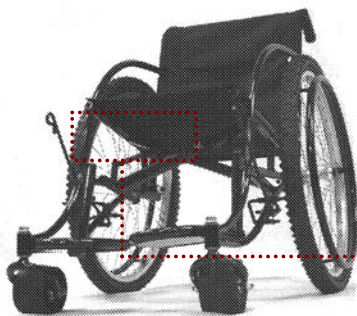

Reinforcement Welded  
Under Seat Tube

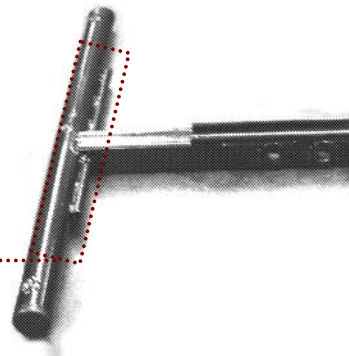

**Solution:** This repair requires two people. Clamp the square tube (cross tube) in a vise. Slide two long (50-80cm) strong, thick-walled tubes over the ends of the bent seat tube until they are both touching the square tube. At the same time, both people should carefully push (or pull) in the opposite direction that the seat tube bent. Continue until the seat tube is straight. Hammering the ends of the seat tube outward can correct the problem. If the side frame bends inward again, get a good welder to re-align the entire X-brace and reinforce both seat tubes by welding in reinforcing rods under the seat tube.





